

ELCU-100 Emergency Lighting Control Unit

Installation Instructions

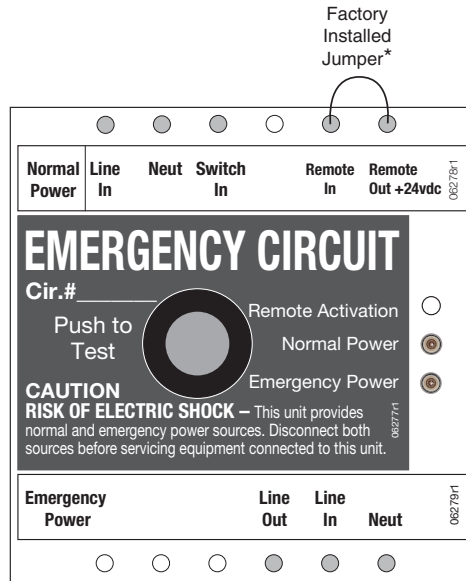

SPECIFICATIONS

Voltages.....	120/277VAC 60Hz
Max Load Requirements	
Ballast.....	10A @277VAC
Incandescent.....	2A @120VAC
Motor.....	1HP @120VAC
Remote Activation.....	24VDC sourced, dry contact closure
Integral Control.....	Push-to-Test button on unit
Conformance.....	UL924, NEC, OSHA, NFPA life safety codes
Environment.....	32°-122°F (0°-50°C) Ambient
Terminal Torque	4.428 inch pound-force (0.5Nm)
Dimensions	2.78" x 3.44" x 2.63"
.....	(70.61mm x 87.38mm x 66.80mm)



Santa Clara, CA 95050



IMPORTANT SAFEGUARDS

When using electrical equipment always follow basic safety precautions, including:

- a) **READ AND FOLLOW ALL SAFETY INSTRUCTIONS--SAVE THESE INSTRUCTIONS**
- b) Mount only in an industrial control panel with a DIN rail mounting system.
- c) Do not use near gas or electric heaters.
- d) Equipment should be mounted in locations and at heights where it will not readily be subjected to tampering by unauthorized personnel.
- e) Use of accessory equipment not recommended by the manufacturer may cause an unsafe condition.
- f) Do not use this equipment for other than intended use.

DESCRIPTION

The ELCU-100 Emergency Lighting Control Unit allows lighting control devices for normal lighting to also control emergency lighting installed within the area. The ELCU is designed for lighting control in areas where emergency lighting fixtures are connected on dedicated emergency lighting circuits that are typically ON 24 hours per day. The ELCU allows ON/OFF control of the emergency lighting along with the normal room lighting to save energy.

The intended operation of the ELCU is to guarantee that the emergency lighting is ON whenever normal power to the controlled circuit is interrupted. While normal power is present, the ELCU allows control of the emergency lighting by a device such as an occupancy sensor, a relay, a dimmer, or a wall switch.

Call 800.879.8585 for Technical Support

WIRING

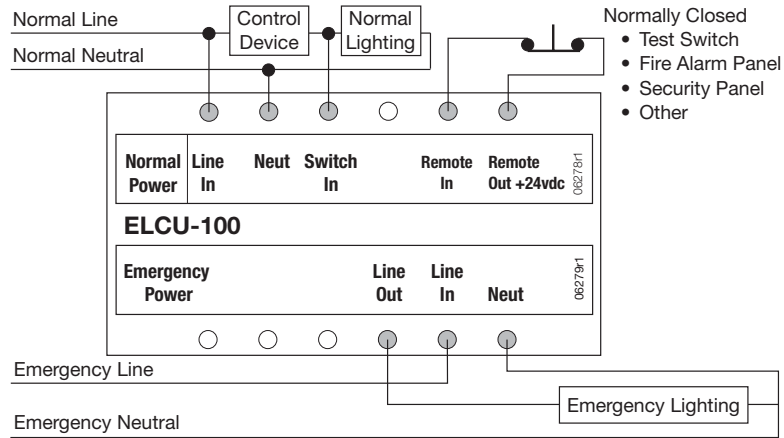

Standard wiring for switched control of emergency lighting along with normal lighting

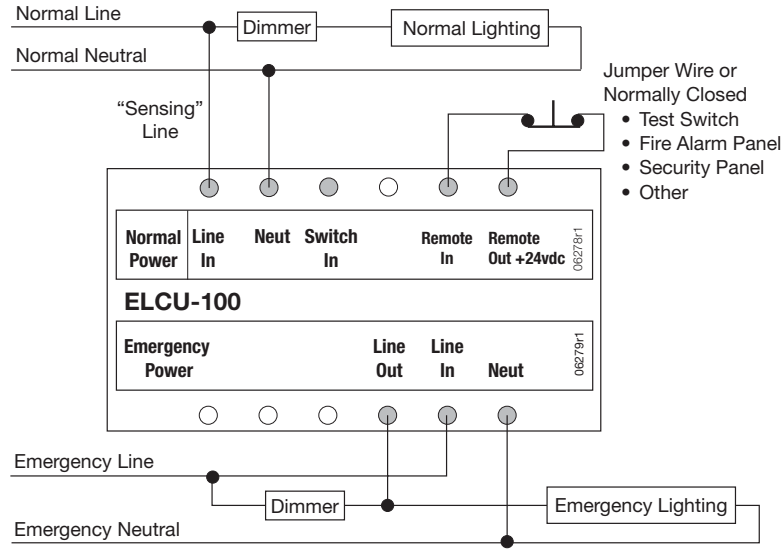

Alternate wiring for dimmer bypass on an emergency circuit

INSTALLATION

- ELCU units should be installed in accordance with state, local and national electrical codes and requirements.
- ELCU units are designed to attach to lighting control panels or electrical enclosures that are fitted with a DIN-rail, such as a Watt Stopper accessory enclosure (LS-E8, LS-E12), or any Watt Stopper lighting control panel fitted with the DIN rail mounting option.
- ELCU units operate with power provided by two sources. Place a warning label on each enclosure that contains an ELCU unit.

Installation Procedure

1. Snap the unit onto the DIN-rail. A distinct click indicates the unit is locked in place. If more than one unit is being installed in the same enclosure, mount the units so the emergency power connections for all the units are on the same side to maintain separation of normal and emergency wiring.
2. Connect the ELCU to the emergency lighting for the area controlled. Connect the Line In and Load Out terminals on the ELCU in series with the emergency lighting load as shown in the wiring diagram. Connect the neutral for the emergency circuit to the Emergency Power Neut terminal as shown in the wiring diagram.
3. Connect the ELCU to the control device for the area controlled. Connect the Normal Power side of the ELCU to the normal lighting circuit as shown in the wiring diagram. Note that the Line In connection should be made to the line side of the control device that serves the same area as the emergency lighting. This ensures that the emergency lighting turns ON during a localized power failure affecting only the portion of the building where the ELCU is installed.

Installing the Optional Remote Activation Device

The ELCU provides terminals for connection of a remote device that can force the unit into the emergency ON mode. A factory installed jumper connected between the Remote In and Remote Out terminals on the ELCU disables this function. Do not remove this jumper unless remote activation is desired. The device that provides remote activation of the emergency ON mode must provide a normally closed, maintained contact dry contact closure. The remote device opens the contacts to force the ELCU into the emergency ON mode.

The most common remote device is a test switch that is installed in an accessible location. Alternately, these terminals can be used to allow another system such as a fire alarm or security system to force the ELCU into the emergency ON mode.

1. Remove the factory installed jumper from the Remote In and Remote Out terminals.
2. Connect the Remote In and Remote Out terminals on the ELCU to the single pole contacts on the remote device or test switch. The device must provide normally closed, maintained contact dry contact closure. The remote device opens the circuit in order to force the ELCU into the emergency ON mode.

TESTING

Initial testing should be done with the Remote In/Remote Out jumper in place to limit the possibility of a remote device affecting the testing.

1. Turn ON the circuit breaker in the emergency panel for the controlled circuit. The green LED on the ELCU should glow. With only the emergency circuit ON (normal power OFF) the emergency lighting should be ON.
2. Temporarily disconnect and cap the wire connected to the Switch In terminal on the ELCU. This disables the normal control function and allows definitive testing of the fail-to-ON functionality.
3. Turn ON the circuit breaker in the normal panel for the controlled circuit. The amber LED glows indicating that normal power is present and that emergency lighting is not required. The emergency lighting should turn OFF. Confirm the automatic emergency ON functionality by turning OFF the normal circuit breaker. The emergency lighting should immediately turn ON.
4. With the normal circuit breaker OFF, re-connect the wire to the Switch In terminal. Turn ON the normal circuit breaker. The control device now controls both the normal and emergency lighting together.

Remote Activation Test

1. Connect the Remote In and Remote Out terminals on the ELCU to the single pole contacts on the remote device or test switch. With the remote device in normal mode (contacts closed) the red LED on the ELCU is ON and the unit operates just as it did with the factory jumper installed.
2. When the remote device activates (for example, push the test switch) the red LED extinguishes, indicating a true test condition. The ELCU is forced into the emergency ON mode and the green LED glows brightly.

WARRANTY INFORMATION

Watt Stopper/Legrand warrants its products to be free of defects in materials and workmanship for a period of five (5) years. There are no obligations or liabilities on the part of Watt Stopper/Legrand for consequential damages arising out of, or in connection with, the use or performance of this product or other indirect damages with respect to loss of property, revenue or profit, or cost of removal, installation or reinstallation.



2800 De La Cruz Boulevard, Santa Clara, CA 95050

Technical Support: 888.817.0571

www.wattstopper.com

06275r2 10/2006